

BTF040



CC_006-6

PLANETARY MIXER 40 LITERS	
Bowl capacity (l)	40
Emulsion (l)	10
Creams without emulsion (l)	20
Creams with emulsion (l)	12
Bread dough (flour)* (Kg)-(lb)	8 (17,64)
Shortcrust pastry (dough) * (Kg)-(lb)	12 (26,46)
Power (kW)-(hp) 230/110V-1ph-50/60Hz 400V-3ph-50/60Hz	2,2 (3) 1,5 (2)
Power lifting (kW)-(hp) 230/110V-1ph-50/60Hz 400V-3ph-50/60Hz	0,25 (0,3) 0,25 (0,3)
Hub attachment power (kW)-(hp) 230/110V-1ph-50/60Hz 400V-3ph-50/60Hz	0,55 (0,75) 0,55 (0,75)
Net weight (Kg)-(lb)	203 (447,53)
Dimensions (mm)-(in)	A 600 (23 5/8) B 950 (37 3/8) C 1340 (52 3/4)



* Based on: 60% dough hydration, 125 flour moisture, 2°C water

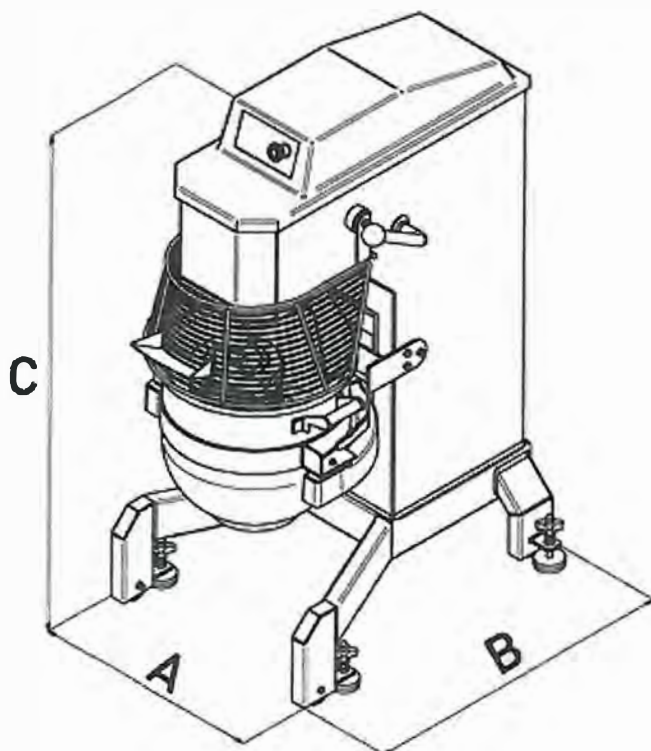

**Reward
Hospitality**

Contact our team for enquiries.

Commercial: 0800 428 733 | Domestic Products: 0800 697 465 | Service: 0800 178 349

www.rewardhospitality.co.nz